

ER52 - Evaporator Controller

Electronic Refrigeration Line

Product Bulletin

Devices are standalone digital controller for "static" or "ventilated" refrigeration units working at positive temperatures.

They incorporate comprehensive controls to apply controllers with food display cases or any evaporator units.

Devices can be used also as heating thermostat.



Physical Features

- Robust front panel for durability and long term usage
- Direct 230V supply: no external transformer required
- High power relays: direct compressor command

Application Features

- Cooling or heating thermostat
- Pre-set models and selectable options to extend pre-set models
- Comprehensive controls: compressor, fan, defrost, light, alarms, door, standby
- Temperature monitoring: minimum and maximum peaks
- Sensor selector: NTC or PTC

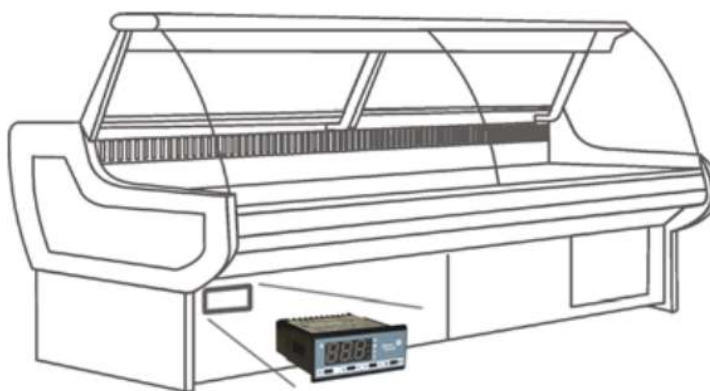

Dimensions (in mm) and Mounting

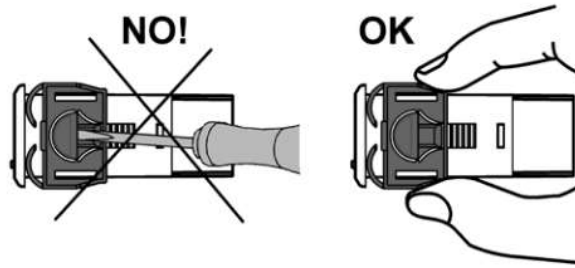
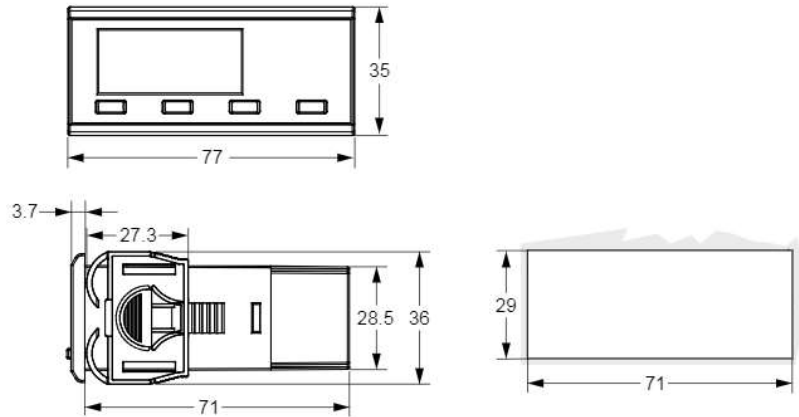



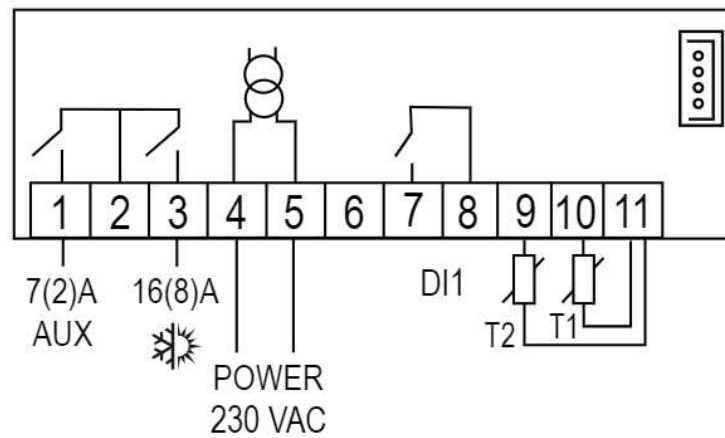











Wirings



T1 = Return air temperature
T2 = Evaporator temperature

Functions

Device Features	Description
 Positive Temperature	It integrates all the functions to face refrigeration units at positive temperature. It can be also used as heating thermostat. Pre-set models are selectable from the display.
 Keyboard Lock	Display can be locked in order to prevent user to change parameter settings. When locked, only temperature information is available to the user.
 Direct Power Supply	Devices are powered directly with 230 VAC.
 Multifunction Input (DI1)     	Digital inputs are available to manage alarm contact, door contact or remote commands such standby, defrost, night or forced ventilation.
 Auxiliary Output (AUX)    	Auxiliary relays are available to manage optional outputs such light, alarm report, defrost or fan.
 Temperature Monitoring (Min/Max)	Device monitors the current temperature every 5 minutes and memorizes the minimum and maximum peaks. Peaks values are visualized on display temperature menu.

Control Features	Description
 Thermostat Control Cooling or Heating	<i>See detailed description hereafter.</i>
 Fan Control	
 Defrost Control	
 Light Control	
 Temperature Alarm (High-Low)	



Thermostat Control

Thermostat is off when temperature reaches the setpoint. Request turns to On if temperature increases below the setpoint + hysteresis on cooling or decreases under the setpoint-hysteresis on heating. Thermostat output activation could be delayed in order to prevent from frequent on-off switching (advised when thermostat drives a compressor).

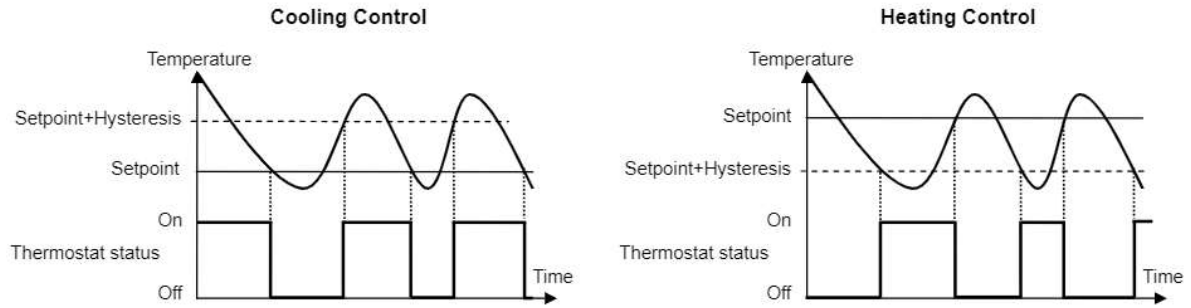

Compressor start time

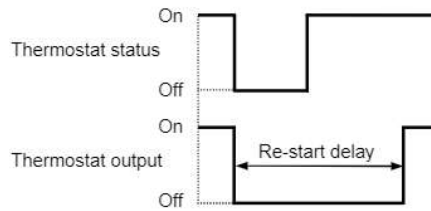

Setpoint

Setpoint is blocked between minimum and maximum values to limit user setpoint adjustment. A second setpoint can be defined to save energy during night or reduced load periods. Periods are defined by external digital input command.

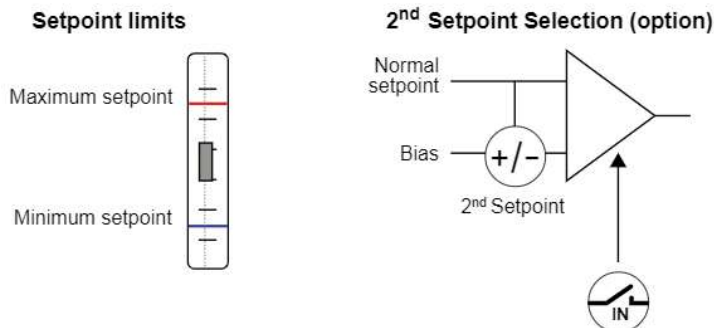



Fan Control

Fan is optional and can be activated on the auxiliary relays. It works in parallel to the compressor and is immediately stopped when door is opened. Fan is forced to on during defrost cycle.



Defrost Control

Defrost cycles are defined by setting the defrost initialization/end conditions and operations during defrost.

Defrost operation

Off cycle: unit is stopped and temperature naturally increases.

Electrical: unit is stopped and electrical heater is activating.

Hot gas: compressor is running and cool cycle is reversed by activating hot gas valve.

Defrost Start

Defrost can be initialized periodically based on time. Manual action is also available from display front panel or wired remote switch. Defrost starts at first occurrence of time or manual events.

Periodical Defrost

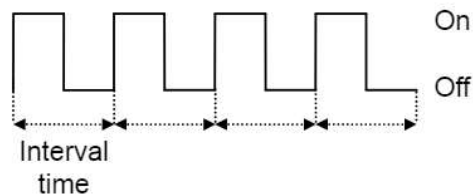

Manual Defrost

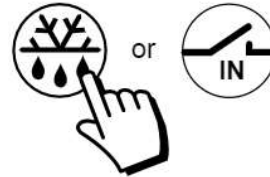

Defrost stop

Defrost cycle ends based on a maximum duration time. Evaporator sensor could be used to stop the defrost before maximum time occurs. A dripping period can be also added to the defrost cycle in order to fill the evaporator with possible condensation.

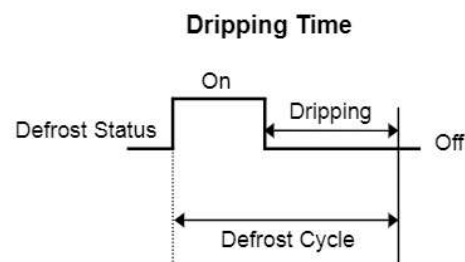
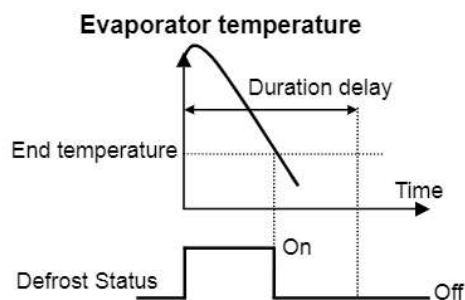



Light control

It can be activated on the auxiliary output. Light command is piloted from front panel key or wired door switch. Light is switching at opening of the door.

Manual switching



Door switching

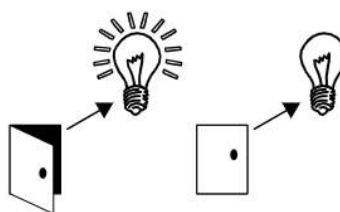

Standby/Fan only mode

Unit can be fully stopped by standby commands available on display front panel or wired remote switch. Alternatively unit can be partially stopped by maintaining only the internal ventilation (fan only mode).

Name	Input	Output
Standby mode	Front panel key or digital input	All outputs Off
Fan Only mode	Digital input	All outputs Off except fan

Alarm Management

Table sums up all the alarms managed by the devices.

Name	Input	Output
High temperature	Temperature	No action on control - Alarm output activated
Low temperature	Temperature	No action on control - Alarm output activated
Interlock alarm	Digital input	All control outputs off - Alarm output activated
Report alarm	Digital input	No action on control - Alarm output activated
Door open	Digital input	Specific management (see below) - Alarm output activated
Sensor Failure	T1 sensor	All control outputs off - Alarm output activated



Temperature alarm

Alarm is detected if temperature moves outside low and high thresholds. Alarm activation could be delayed in order to consider temporary fluctuations due to specific operations such start up or defrost. Thresholds are independent from the setpoint (absolute alarm). Alarm situation is ending when temperature turns back between low and high thresholds.

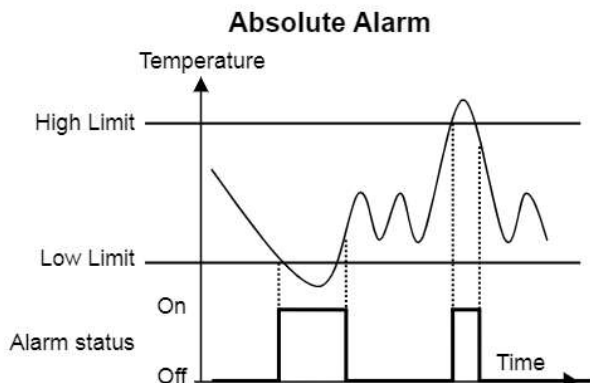

Door open

Specific strategy is applied when door is opened:

Door alarm is delayed to prevent from quick opening/closing of the door. Alarm becomes active when the delay ends.

Compressor stop can be delayed.

Fan is stopped.



Alarm Outputs

Alarms are reported on display front panel LED, internal buzzer or auxiliary output. Alarm is reset automatically.

Alarm Activation



Display alarm LED



Internal Buzzer (option)



Auxiliary Relays (option)

Buzzer mute



Display layout



ER52 Display

- Alarm LED
- Thermostat / Compressor LED
- Defrost LED / Command
- Light LED / Command
- On / Standby Command
- Alarm mute
- Menus navigation

Display Menus

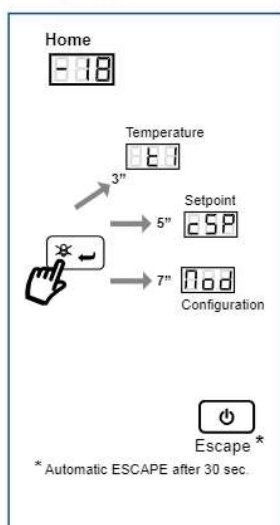

Menus Navigation

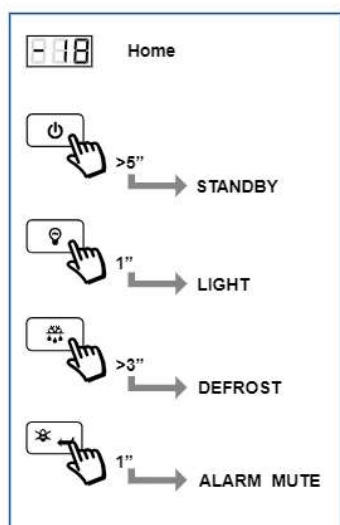

Function Keys

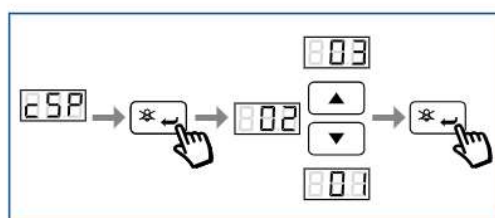

Parameter Setting Example

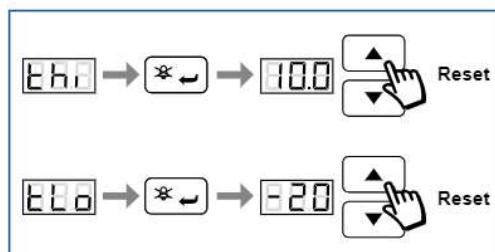

Min/Max Temperature reset

Temperature Menu

Code	Description
t1	Return air temperature
t2	Evaporator temperature (visible only if selected)
thi	Monitored temperature highest peak
tLo	Monitored temperature lowest peak
Loc	Keyboard lock parameter

Setpoint Menu

Code	Description
cSP	Setpoint

Messages and Error Codes

Code	Description	Action
F1	t1 sensor failure	To check t1 wiring or replace it
F2	t2 sensor failure	To check t2 wiring or replace it
A1	General alarm	To resolve alarm cause
A2	Report alarm	To resolve alarm cause
A3	Door open	To close the door
Fon	Fan only mode	To reset fan only mode with Digital Input
oFF	Standby	To restart unit with keyboard or Digital Input
d	Defrost active	To wait defrost completion
hi	High temperature alarm	To check plant (abnormal temperature)
Lo	Low temperature alarm	

Configuration Menu

Code	Default	Range	Description
Setup			
Mod	rEF	rEF / hEA	Application selector: cooling (rEF), heating (hEA)
St	ntc	ntc, A99	Sensor types
un	1 °C	0 °1, 1 °C, 1 °F	Scale selector: °C (decimal), °C (degree), °F
 WARNING: Setup parameters have to be defined before setting the configuration parameters. Any new setup could recover default settings.			
Thermostat Control			
LL	-40	-40 / hL	Setpoint Low Limit
hL	70	LL / 70 °C	Setpoint High Limit
cSP	2 (40*)	LL to hL	Setpoint
hY	2	0.5 / 10 °C	Hysteresis
cc	3	0 / 10 min	Compressor Min Off time
Sc	2	0 / 10 min	Compressor stop delay at door opened
Temperature Alarm Setting			
ALA	-40	-40 / 70 °C	Absolute alarm low limit
AhA	70	-40 / 70 °C	Absolute alarm high limit
At	30	0 / 120 min	Alarm delay at normal operation
AbE	no	no, YES	Alarm buzzer enable
Defrost Setting			
dS	tiM (no*)	no, tiM	Defrost selector: not used, periodical
di	06	1 / 168 hours	Defrost periodical interval
dF	oFF	oFF, ELE, hGA	Defrost operation: off cycle, electrical, hot gas
dt	7	-40 / 70 °C	End defrost temperature
dd	40	1 / 99	Defrost maximum duration
dc	0	0 / 99	Defrost dripping time
dP	Lt	Lt, SP, dF	Display value on defrost: last temperature, setpoint, Defrost flag
dr	20	0 / 99	Display delay after defrost

Code	Default	Range	Description			
Multi function Input Setting						
IF1	00	00 / 07	Digital input 1 selector: 00 = Not used 04 = 2 nd setpoint 01 = Interlock 05 = Standby alarm 06 = Fan only 02 = Alarm mode report 07 = Defrost start 03 = Door			
			id1	5	0 / 99 min	Digital input 1 delay (alarms, door)
			bio	0	-12 / 12 °C	2 nd setpoint (bias)
			LGS	MAAn	no, MAAn, dor	Light switch command: not used, manual, door opened
SbE	YES	no, YES	Standby key enable			
Probe Setting						
SF1	3	0 / 10 min	Compressor On time at sensor failure			
SF2	3	0 / 10 min	Compressor Off time at sensor failure			
So1	0	-12 / 12 °C	Sensor T1 offset			
SE2	no	no, YES	Sensor T2 enable			
So2	0	-12 / 12 °C	Sensor T2 offset			
Display Setting						
Pu	3	0 / 100	Display refreshing time			
Auxiliary Output Setting						
AA1	LGt	no, AL0, AL1, LGt, dEF, Fan	Auxiliary output 1 and 2 selectors no: Not used LGt = Light AL0 = Alarm at command opening dEF = Defrost output AL1 = Alarm at Fan output closing Fan =			

* Default values of Mod = hEA (heating)

Ordering Codes

All ordering codes are relative to individual product package.
All items are also available with bulk pack (i.e. quantity of 10 controllers). Please refer to JC customer service.

Controllers

ER52-PM230-501C	Controller, 1 NTC sensor included
-----------------	-----------------------------------

Accessories & Spare parts

ER-NTC-0C	NTC Sensor, 2 m, universal replacement
-----------	--

Technical Specification

Product Codes	ER52-PM230-501C
Power Requirements	230 VAC/VDC \pm 10%, 50/60 hZ, 3 W
Protection Class	IP55 (front) - IP20 (back)
Ambient Operating Conditions	-10 °C to 50 °C 15 to 80% RH (non-condensing)
Range	-40 to 70 °C
Accuracy	+/- 1K
Sensor	NTC, A99
CE Conformity	Johnson Controls, Inc., declares that these products are in compliance with the essential requirements and other relevant provisions of the EMC Directive 2004/108/EC, Low Voltage Directive 2006/95/EC.